

VT ElektroPlast

ONE COMPANY – INFINITE POSSIBILITIES

—
Engineering

TECHNOLOGY

DYNAMISM

PROGRESS

STABILITY

WIDE RANGE OF ENGINEERING SERVICES



- feasibility studies, DFM analysis
- product development with the customer - early involvement
- creating prototypes
- tool management
- automation: assembly lines, single-purpose machines
- industry 4.0
- 15 mechanical engineers, 7 electrical engineers, 3 IT engineers, 2 IT technicians
- 15 designer stations
- Mechanical CAD softwares: Creo 5.0, NX 10, SolidEdge 10, Solidworks 2023
- Electronic softwares: E-Plan, Lab View, Protel, WinSTEP, Altium

NPI FUNCTIONS

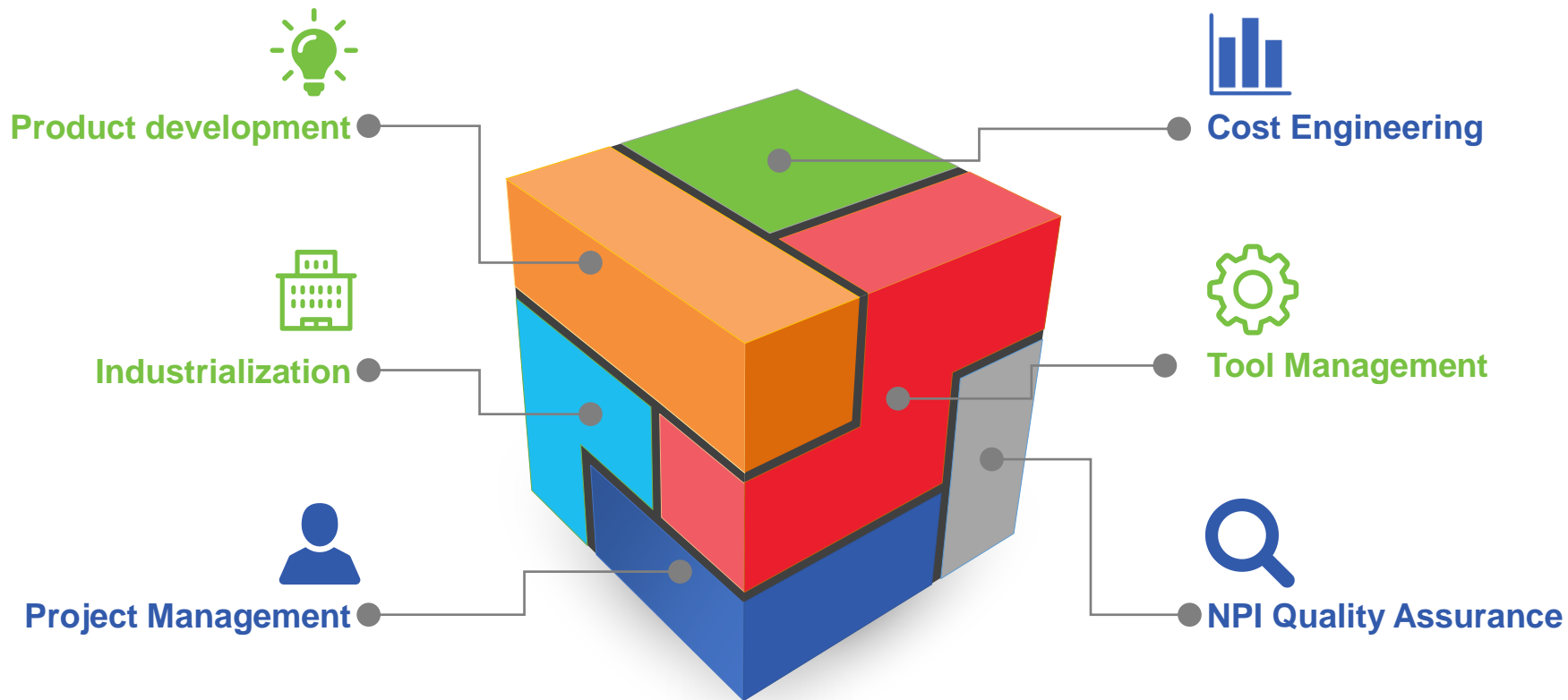

NPI CAPABILITIES AND SERVICES

VIDEOTON internal activities

- product design
- sampling, prototyping
- 3D scanning, printing
- feasibility studies
- functional model
- DFMEA
- mould filling study (DFM)
- mechanical simulation
- electronic design (BMS)
- tolerance chain calculation
- tool management
- assy line design
- tester design
- traceability system
- producing testers
- assy line balance - lean
- PFMEA
- tests (battery, lifetime, durability, climatic)
- measuring and capability reports
- product development study
- FMEA, control plan
- flow chart
- RoHS - XRF tester



Provided by external partners

- market research
- demand map
- concept design
- product design
- ergonomic test
- form design
- function overview
- prototyping
- CE Conformity
- approbation certificates
- (TÜV, VDE, KEMA, GOST-R, CCC)
- RoHS



PRODUCT DEVELOPMENT

CREATING PROTOTYPES

Available prototyping methods

- vacuum-casting
- stereolithography (SLA)
- selective laser sintering (SLS) plastic, metal
- fused deposition 3D modeling (FDM)
- objet/polyjet
- silicon tool/form
- plastic soft tool
- sheet metal parts
- cut parts
- customized rubber parts



TESTS



Test types

- product design tests
- product release tests
- battery tests in separated test lab
- product functionality-related tests
- product performance-related tests
- RoHS compliance
- approbation pre-tests
- internal tests for investigation of quality problems

Battery tests

- (abnormal) charging
- (forced) discharging
- capacity test
- short circuit analysis
- engineering / functional tests
- climate tests
- drum, drop tests

Periodic in-house tests

- kitchen performance test
- durability test
- lifetime test
- high-voltage test
- leakage test
- function test
- switching test
- electronic data collection

POWER TOOL 36V BATTERY PACK

Task: re-design the powertool battery pack existing on the market for the assembly of 21700 cells, functional strengthening of plastic house, design of new accessory component

- product conception suggestion, 3D planning, 2D drawings
- function plan, prototype making, DFM, DFMEA, PFMEA, tooling, sample production
- product tests, release, production

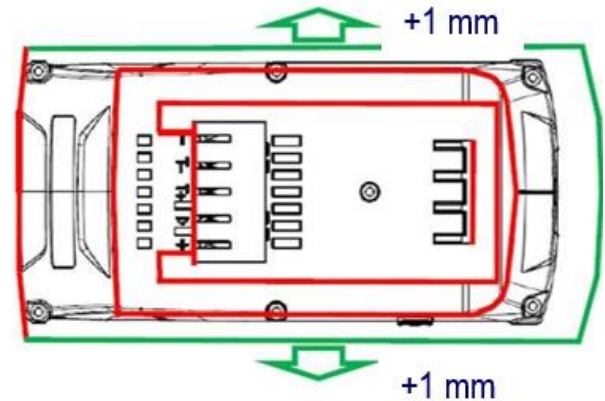
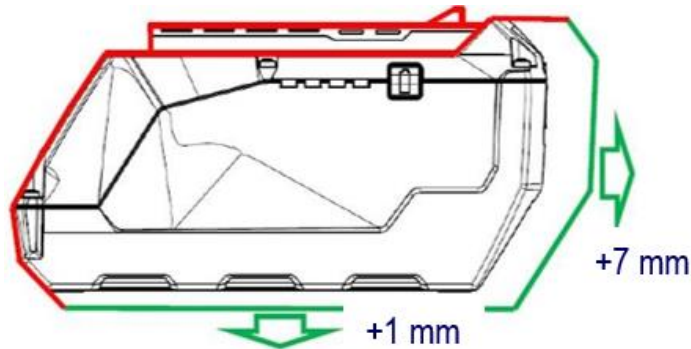

POWER TOOL 36V BATTERY PACK

3D design

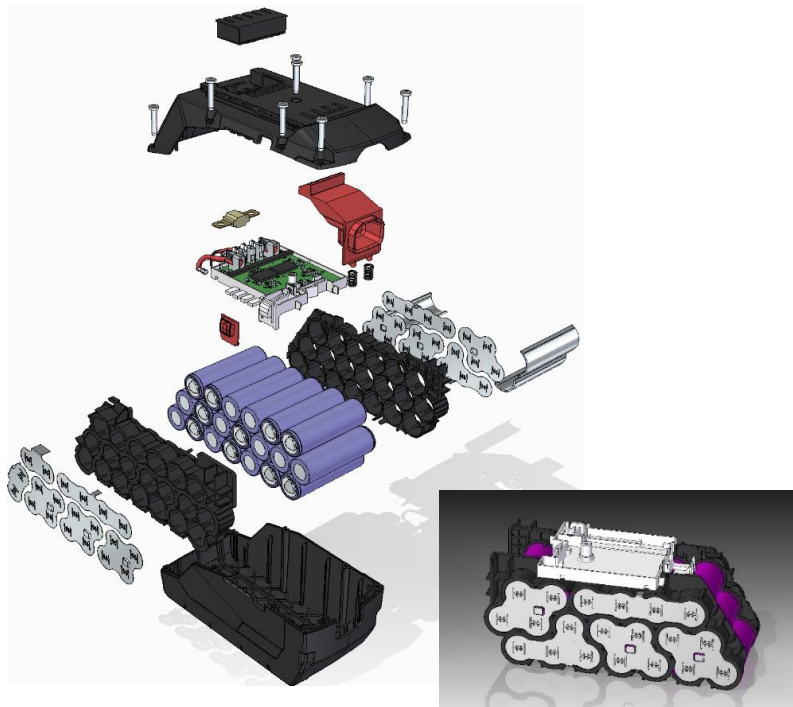

Proto assembly

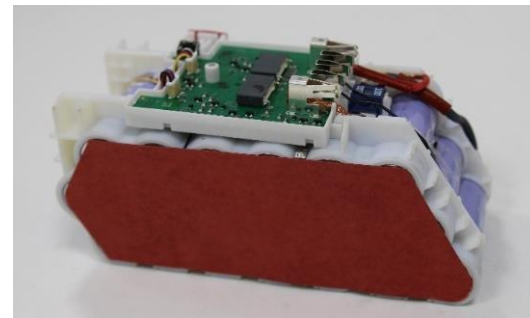

POWER TOOL 36V BATTERY PACK

Designing stronger plastic parts

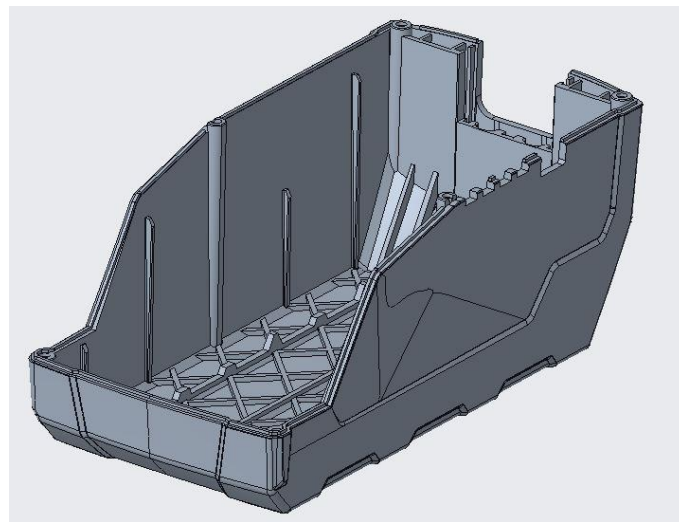
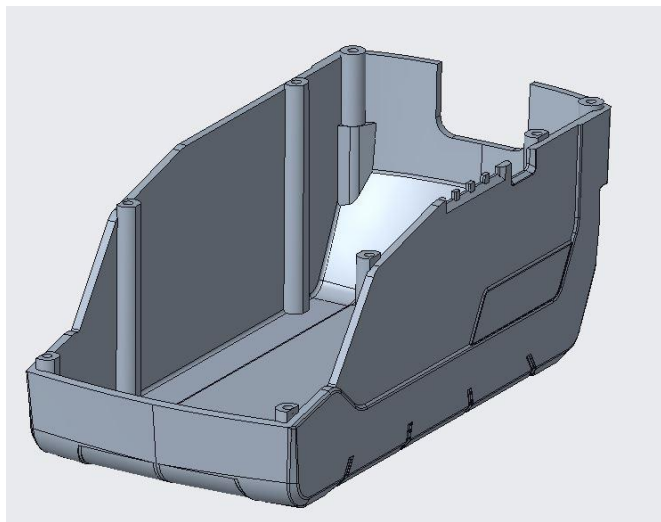

PLASTIC SIMULATION

Solidworks simulation - Premium

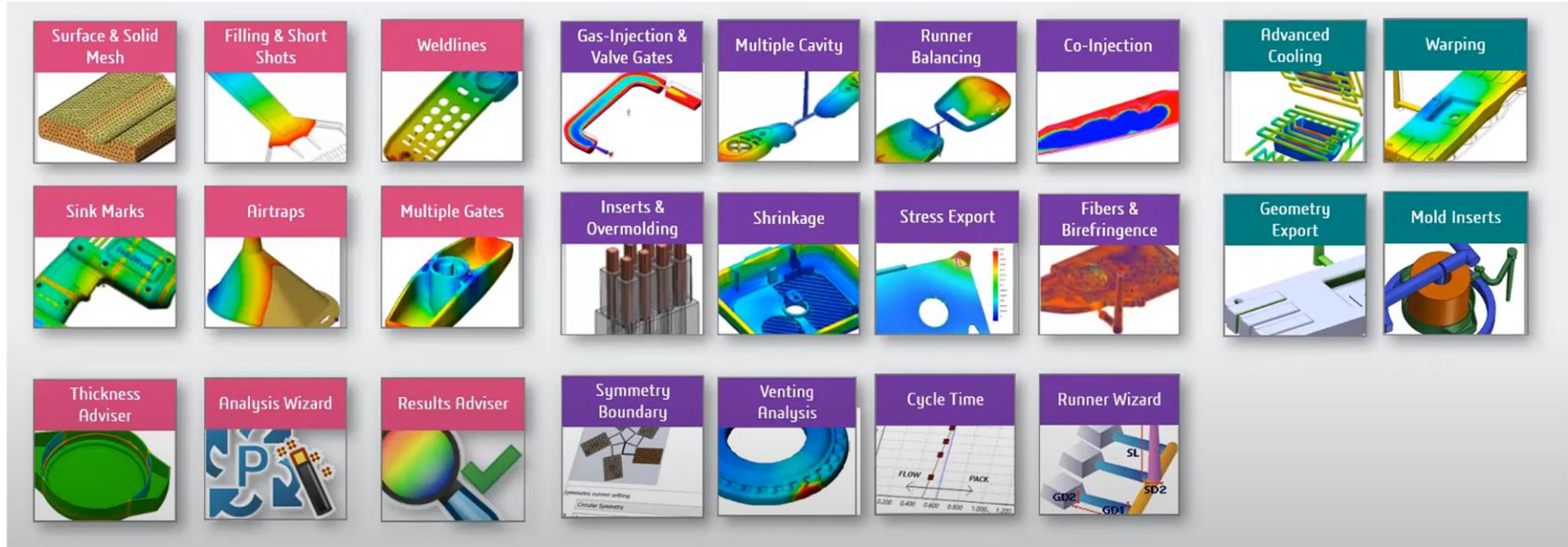

PLASTIC SIMULATION

Filling

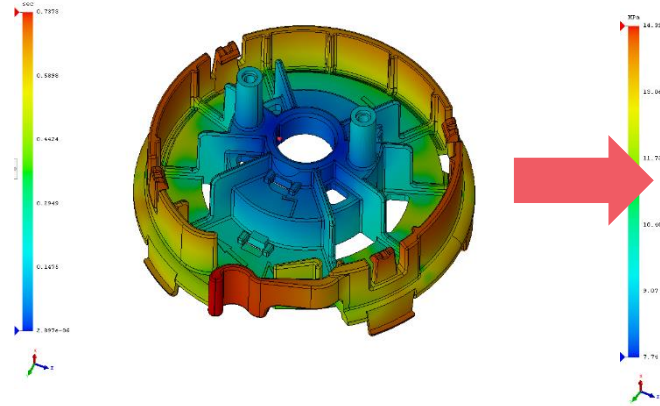

Packing

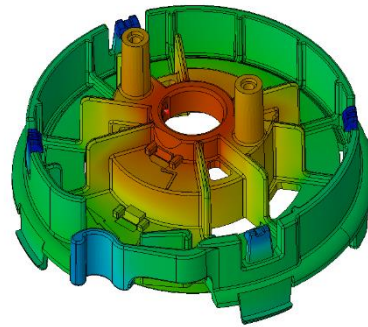

Warping

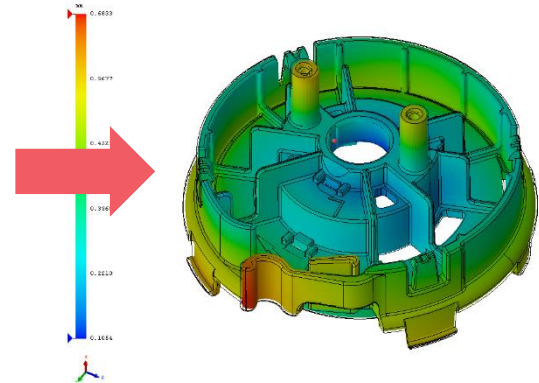

- Weldlines
- Airtraps
- Venting analysis
- Sink marks

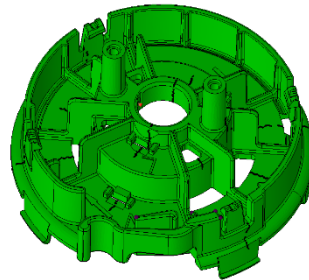

MECHANICAL SIMULATION

Solidworks Simulation - Premium

Simulation Standard

- Linear Static*
- Fatigue
- Motion*
- Trend Tracker

*Part of SOLIDWORKS Premium

Simulation Professional

- Topology
- Buckling
- Frequency
- 2D Mesh
- Optimization
- Thermal
- Drop test
- Sub Modelling
- Materiality
- Event-based motion
- Pressure Vessel
- Load Case Manager

Simulation Premium

- Dynamics
- Composites
- Non Linear
- Random Vibration

MECHANICAL SIMULATION

Displacement: 0,3 mm with both half of the hook

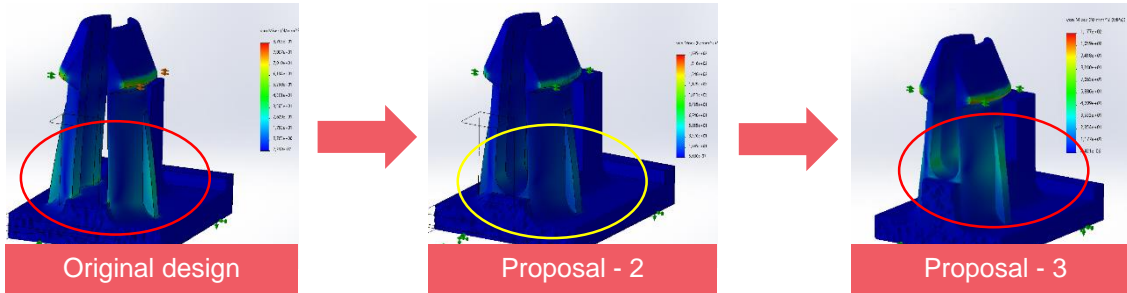

Higher snap fit hook → avoid breaking during assembly - displacement 0,5/0,5 mm

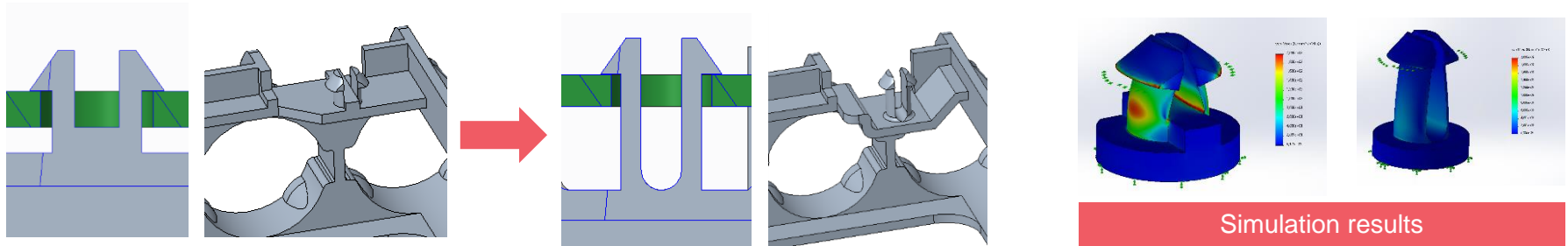

MECHANICAL SIMULATION

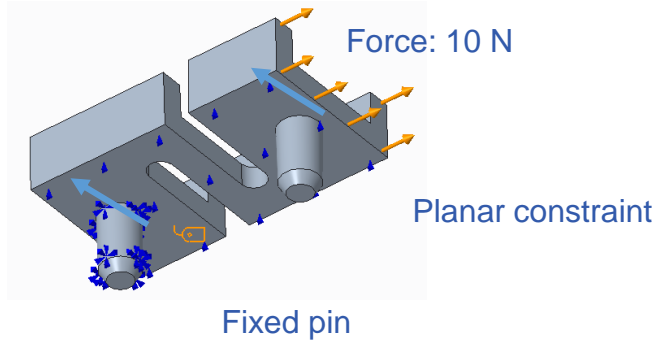

	Original design	Proposal-1	Proposal-2	Proposal-3	Proposal-4	Proposal-5	Proposal-6
<u>Model</u>							
<u>Stress (von Mises)</u>	89 MPa	55,9 MPa	50,7 MPa	69,2 MPa	79,3 MPa	74,3 MPa	46,1 MPa
<u>Displacement</u>	0,678 mm	0,235 mm	0,066 mm	0,497 mm	0,723 mm	0,371 mm	0,170 mm
<u>Result</u>	 Difficult molding Dangerous stress	 Easier molding	 Small displacement	 Difficult molding Weak point	 Easier molding	 Difficult molding	 Small displacement

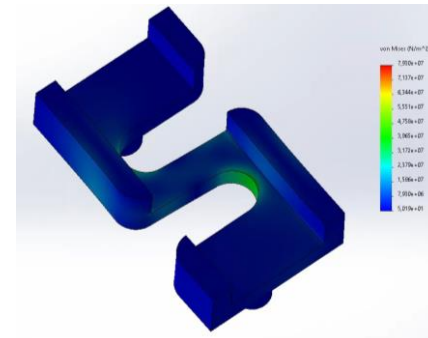
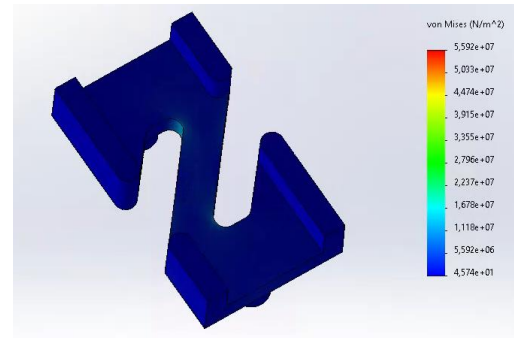
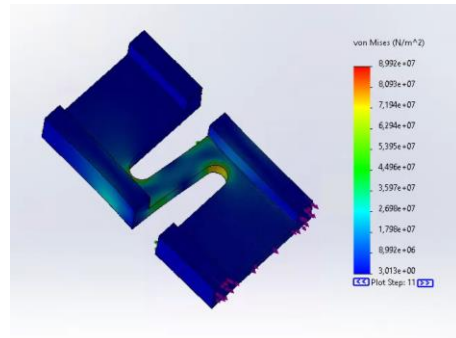

DESIGN FOR MANUFACTURING

Eliminating flexible wires

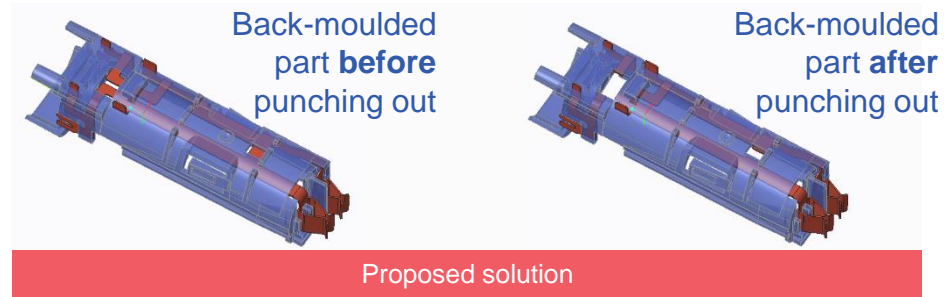
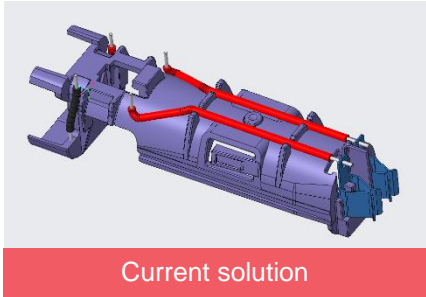

Eliminating additional plastic parts from the original design

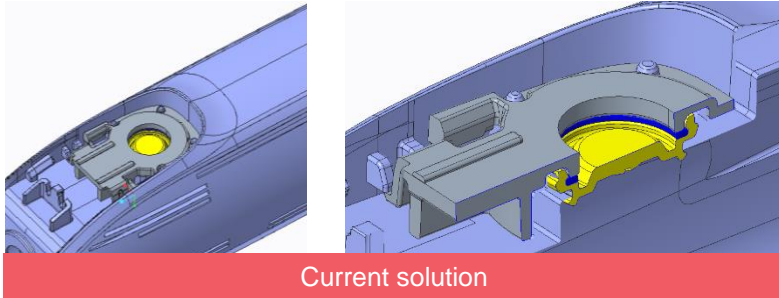

Instead of complex assembly,
simple or complex 2K part

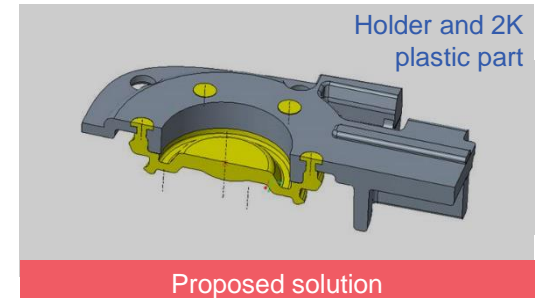

WATERPROOF DESIGN

The waterproof properties of the product can be modified/upgraded with using second component elastic material by plastic moulding

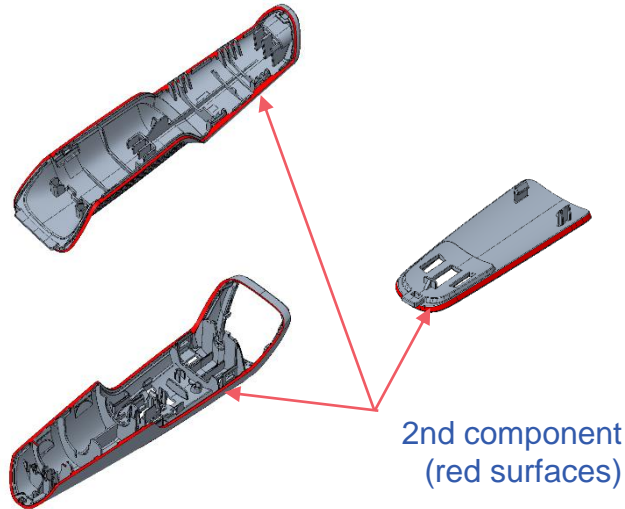

Adding a sealing ring on the excenter rod could also help

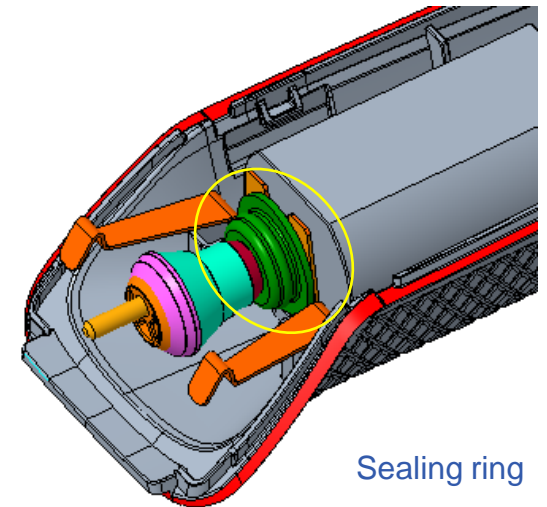

WHEELCHAIR BATTERY UNIT

Concept creation from only the given dimension where the product should fit in

- cell choosing according to the requested electrical parameters
- DFMEA process during the design phase
- electrical and mechanical design capabilities
- align with sub-suppliers to find the best price-value solution
- quick prototyping and evaluation round to not lose time in the design phase
- close cooperation with the customer during weekly technical calls

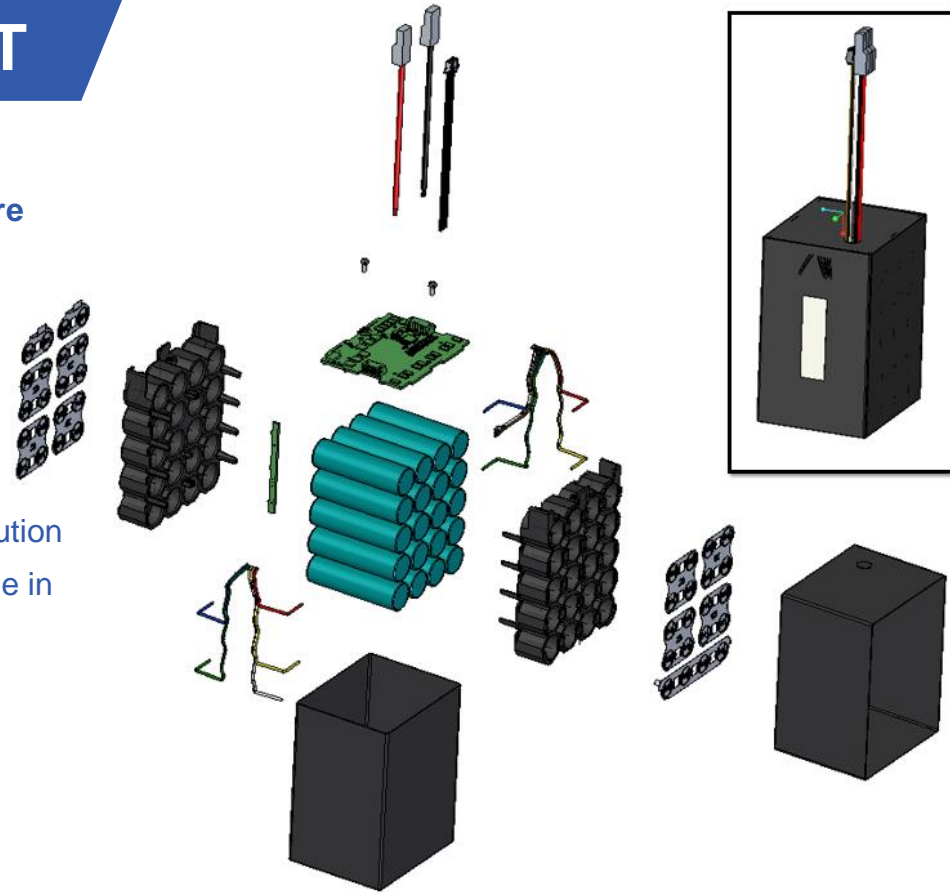

TELEMATIC MODULE BACKUP BATTERY

Backup battery for automotive e-call

- working on this project: 2013-2017
- task: taking active role in designing a 2-cell battery pack
 - feasibility studies
 - sampling (since the first samples)
 - implementing a new technology: laser welding

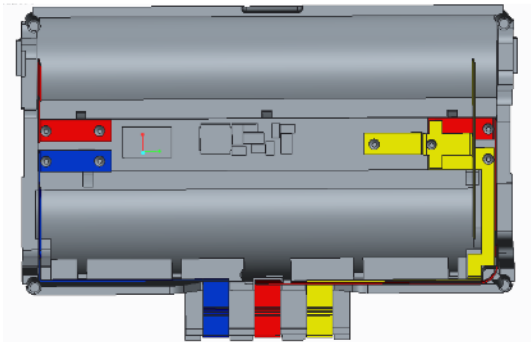

BATTERY-OPERATED EAR CLEANER

Task: designing a portable ear cleaner called Kolibri

- the basic idea, specifying the functions and the product itself
- design
- functional design, prototype
- tests, further development

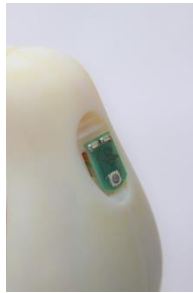

MULTI CHOPPER ADAPTER FOR HAND BLENDER

Task: designing the mechanical inside of the gearbox and taking active role in developing the accessories for production

- 3D mechanical design
- 2D drawings
- tolerance chain calculations
- engineering, kitchen and pre-validation tests, evaluation → constructional changes
- function plan, prototyping
- tests

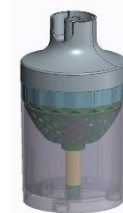
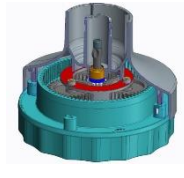
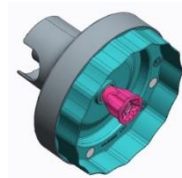

TOLERANCE CHAIN CALCULATION

Input values	(mm)	Calculated values	(mm)
Cell diameter (D)	18,300		
Tolerance window (T1)	0,100		
Contact diameter (d4)	7,450	Minimal useful diameter of the contact	7,350
Tolerance window (T2)	0,200	Minimal useful diameter with position tolerance	7,250
Position tolerance window contact diameter to cell diameter (T3)	0,200	Minimal useful foil diameter	5,300
Insulation foil diameter (d1)	6,000	Minimal useful foil diameter with positioning	5,570
Tolerance window (T4)	0,200		
Technological position tolerance window - foil onto cell (T5)	0,660		
		Minimal useable circle diameter on cell with foil (concentric to A)	5,570
		Nominal (radial) of the insulation foil	
		Minimal (radial) overlap of the insulation foil	
		Maximal (radial) overlap of the insulation foil	
Electrode diameter (d2)	1,400		
Tolerance window (T6)	0,100		
Gap between electrodes X	0,300		
Gap between electrodes Y	0,950		
		Minimum circumscribed circle (d3)	
		Tolerance window (T7)	
Technological position tolerance -welding (T7)	1,000		
		Maximal circumscribed circle diameter for electrodes (concentric to A)	4,900

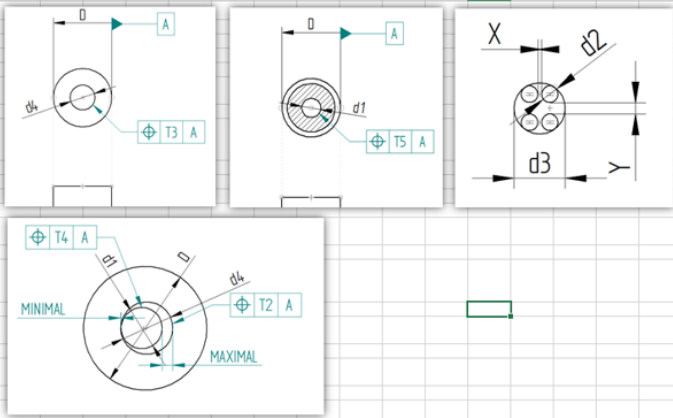

As long as the diameter for the electrodes is smaller than the useable diameter on the cell, there will not be any issues with the assembly.

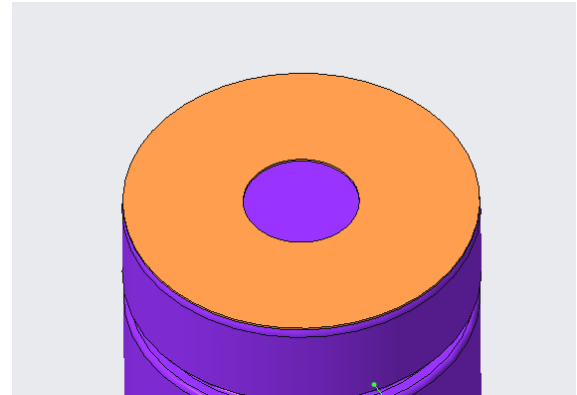

- Capability of the welding
 - arithmetic tolerance check for the related tolerance chain
- Gap variations between batteries and case cover (place for the foam)
 - tolerance chain check

BATTERY MANAGEMENT SYSTEMS - BMS

Active protections with power MOSFETs

- Short circuit
- Overcurrent in discharge and charge mode
- Over- and undervoltage of cells
- Over- and undertemperature in discharge and charge mode

Secondary chemical fuse protection

Cell balancing

Low power mode for storage and transport

Highly configurable parameters

Serial interface for host

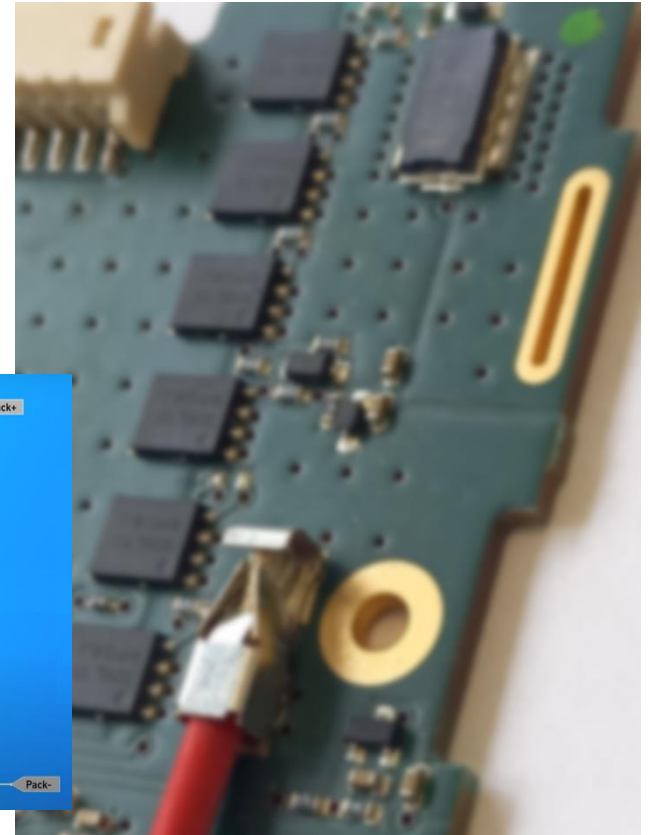
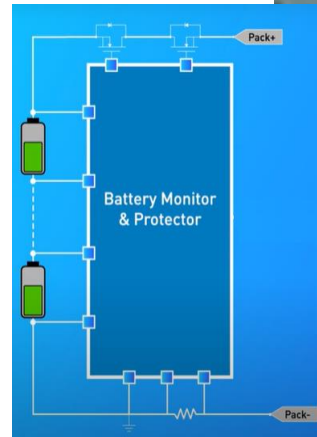



INDUSTRIALIZATION



Play me!

ASSEMBLY LINES

Assembly lines

- manual
- partly automated
- fully automatized

Repairing stations

- for mass production
- for low series production



AUTOMATIZATION & SINGLE PURPOSE MACHINES

- automation of assembly
- testing of certain function(s)
- reliable quality
- stable output
- engineering support for repair
- industry 4.0



IPL HAIR REMOVER – CALIBRATION TEST

- functional operation test
- light energy measurement
- coefficient of correction calculation from the measured values
- calibration via serial port
- traceability system
- two units operating parallelly



HAIR DRYER – EOL TESTER

- parallel testing of two hairdryers
- high voltage withstand test
- measuring performance, temperature and wind speed
- testing of ionizing function
- traceability system
- laser marking



SHAVER CHARGING CENTER

Leakage and function tester

- functional operation test, configuration of different types during testing process, leakage test, checking presence of components
- data collection, laser marking

Automatic assembly machine

- automated assembly of 8 components
- 3 vibrating feeders
- measurement of current consumption
- automatic taking out of ready components
- automatic quality selection

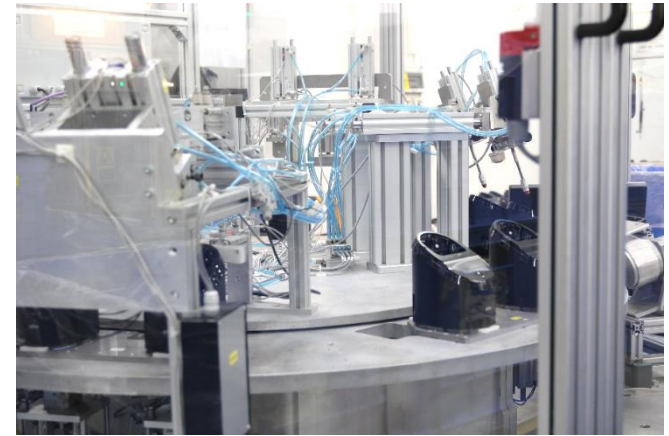

E-CALL BATTERY PACK - DEVICES

Automatic resistance and laser welding

- 3 or 4 position rotary tables
- checking contact position & polarity of cells with a camera
- product presence detection
- QR code reading
- spot welding
- checking welding quality
- laser welding with 2 heads at the same time



E-CALL BATTERY PACK – ASSEMBLY LINE

- a 22-meter long automotive assembly line with ESD area
- 30 pcs of assembly jigs
- 2 pcs of resistance welding machines
- laser engraving, welding machines
- cell tester, ICT tester, EOL tester
- tube filling machine at the packaging part of the line
- QR code readers, camera check
- traceability system



BATTERY – SEMI AUTOMATED ASSEMBLY LINE

12V LiPower and LiHD semi-automated assembly line (3 cells)

- automatic cell balance measurement
- automatic resistance welding
- automatic soldering
- automatic screwing charging, EOL test, laser marking
- moving of packs by robots
- complete monitoring with RFID
(incorporated materials and test results)



BATTERY – SEMI-AUTOMATED ASSEMBLY LINE

18V LiHD semi-automated assembly line (5 and 10 cells)

- automatic cell load with robot, laser marking and balance measurement
- automatic resistance welding
- automatic silicon dosage
- automatic screwing, charging, EOL test, laser marking
- moving of packs by robots
- complete monitoring
(incorporated materials and test results)

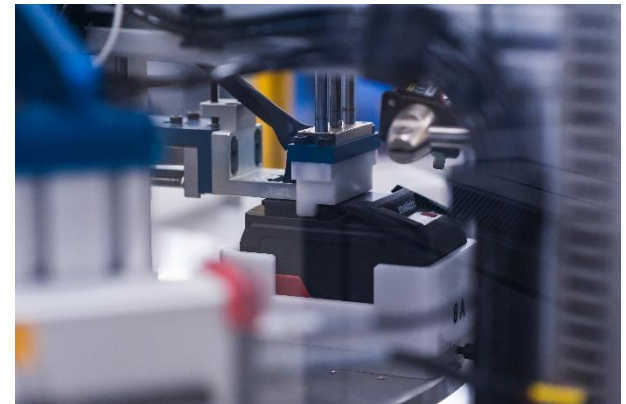

BATTERY – SEMI-AUTOMATED ASSEMBLY LINE



3 cells semi-automated assembly line

- automatic cell load with robot, balance measurement
- automatic resistance welding
- automatic silicon dosage
- soldering of packs by robots
- automatic EOL test, label application, laser marking
- 900.000pcs/year capacity

BATTERY – SEMI-AUTOMATED ASSEMBLY LINE

3 cells semi-automated assembly line

Cell preparation station

- cell balance measurement
- automatic cell label application
- label position control by camera
- automatic cell load with robot



BATTERY – SEMI-AUTOMATED ASSEMBLY LINE

3 cells semi-automated assembly line

Welding station

- automatic resistance welding

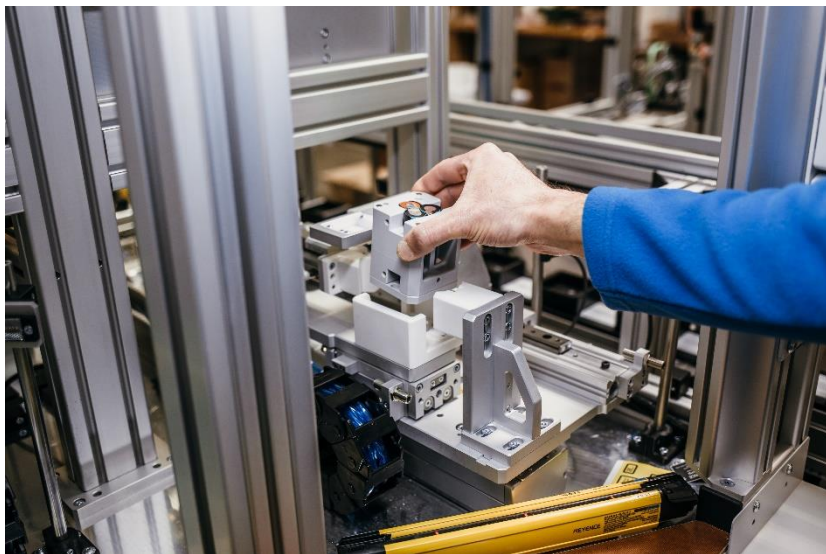

BATTERY – SEMI-AUTOMATED ASSEMBLY LINE

3 cells semi-automated assembly line

PCB assembly station - soldering

- automatic soldering by robots
- automatic soldering quality control by 3D camera
- automatic silicone dispensing by robot

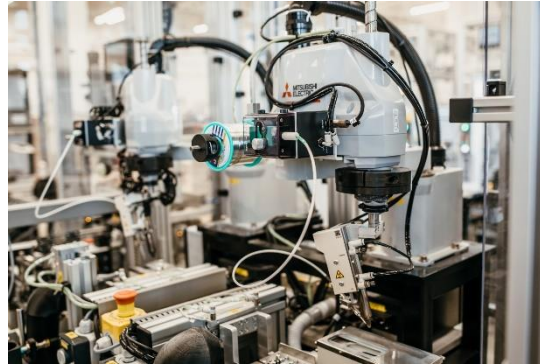

BATTERY – SEMI-AUTOMATED ASSEMBLY LINE

3 cells semi-automated assembly line
Soldering quality control by camera

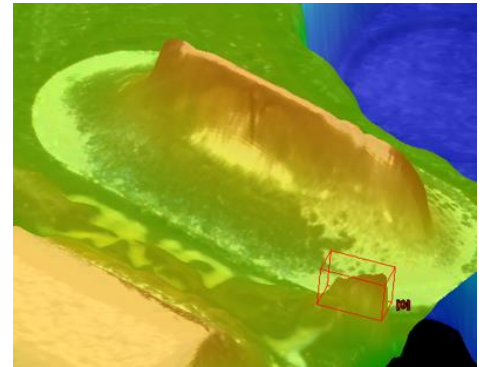
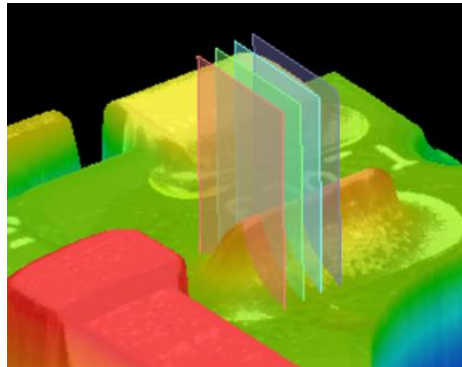
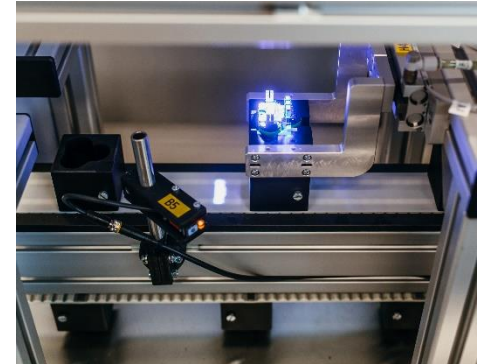
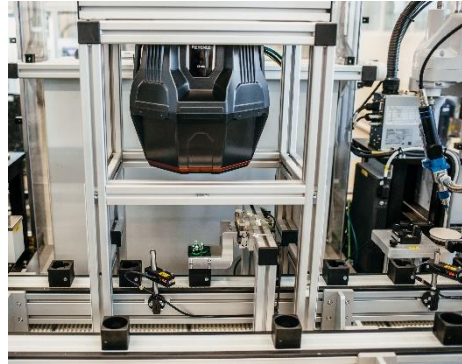

BATTERY – SEMI-AUTOMATED ASSEMBLY LINE

3 cells semi-automated assembly line

End of Line tester

- pack final mechanical assembly
- electrical parameters measuring
- automatic cell label application (2x)
- laser marking



BATTERY – SEMI-AUTOMATED ASSEMBLY LINE

Portable power supply assembly line

Modul assembly line

- automatic cell balance measuring
- automatic cell load
- laser marking
- full traceability system

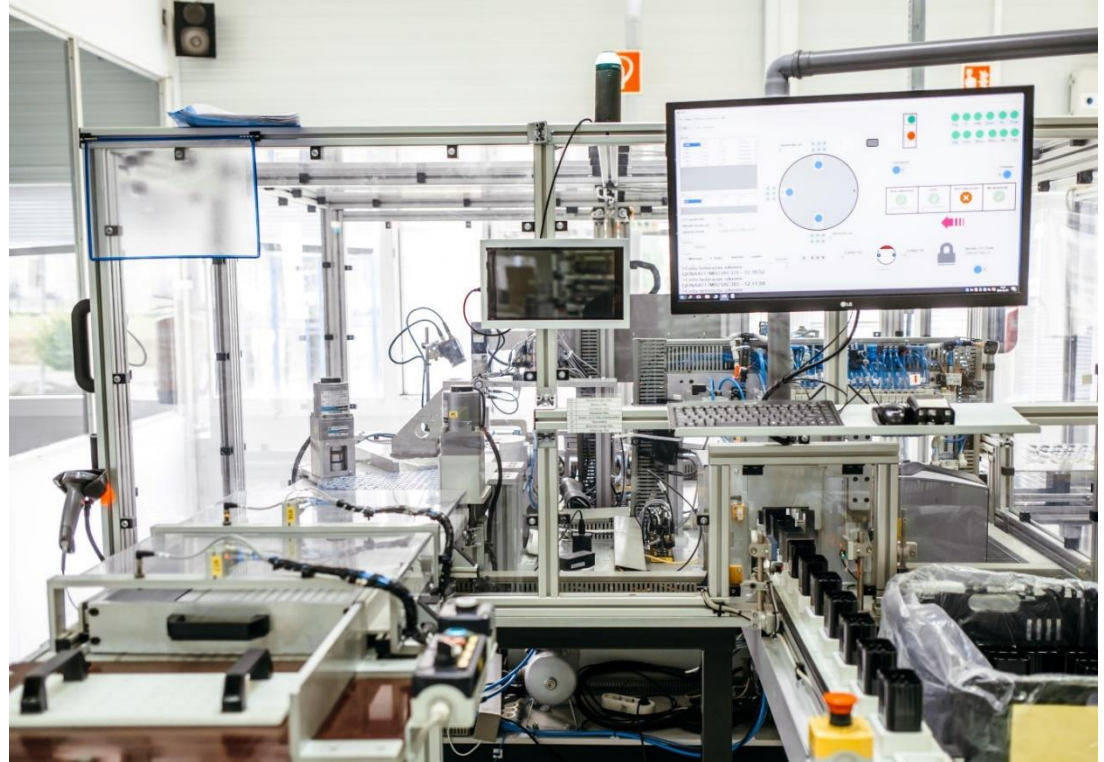

BATTERY – SEMI-AUTOMATED ASSEMBLY LINE

Portable power supply assembly line

- automatic resistance welding stations
- automatic soldering stations
- Automatic End of Line tester



BATTERY – Cell measuring machine

Battery cell measuring and sorting machine

- cell voltage measuring
- greasing
- automatic sorting to trays by robots



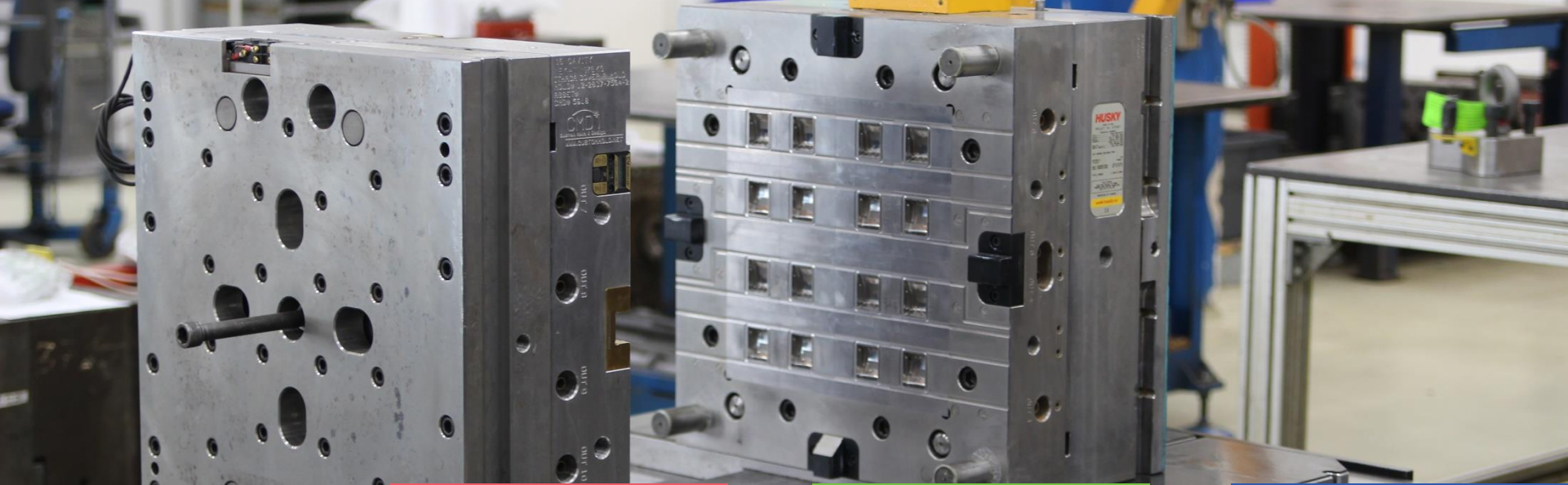

TOOL MANAGEMENT



Play me!

TOOL MANAGEMENT

NPI TOOL MANAGEMENT

- competitive prices: EU & Far-East toolmakers
- complete administration from the model part to tool approval
- DFM
- management of tool modification (including documentation update)
- continuous follow-up of suppliers



INTERNAL TOOL WORKSHOP

- new tool design & production & optimization
- modifications
- Renewals



EXTERNAL PARTNERS

- new plastic
- rubber
- metal tools



DFM Cold runner Pin point

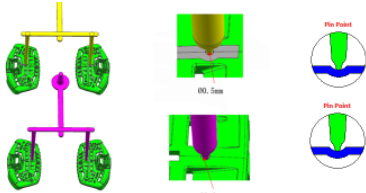

Recessed gating option, final gate size and location will be determined by Moldflow analysis.

DFM Parting line

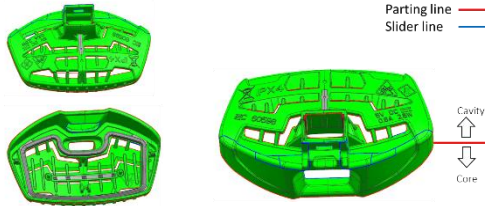

DFM Index plate

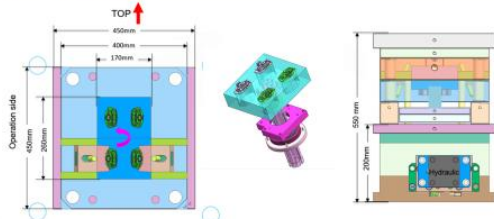

DFM Slider and slider line

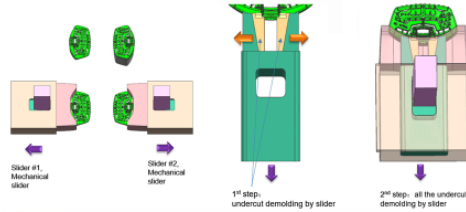

DFM Main parting line – Core insert

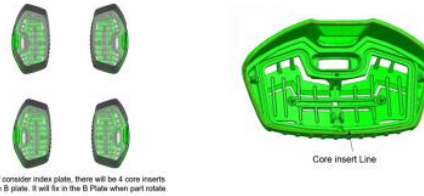

DFM Draft angle analysis

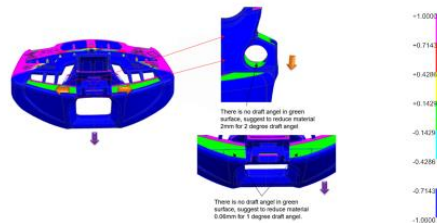

DFM Wall thickness

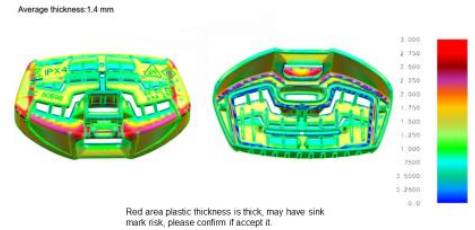

DFM Feasibility issue

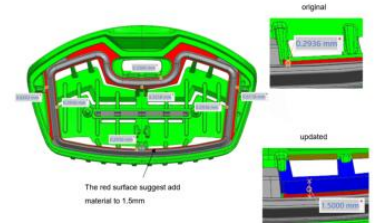

DFM Moldflow analysis

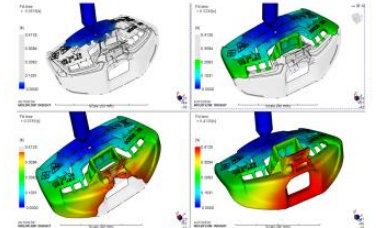

INTERNAL CAD/CAM DESIGN

Software - Siemens NX 10

- tool design & optimization
- modifications
- renewals

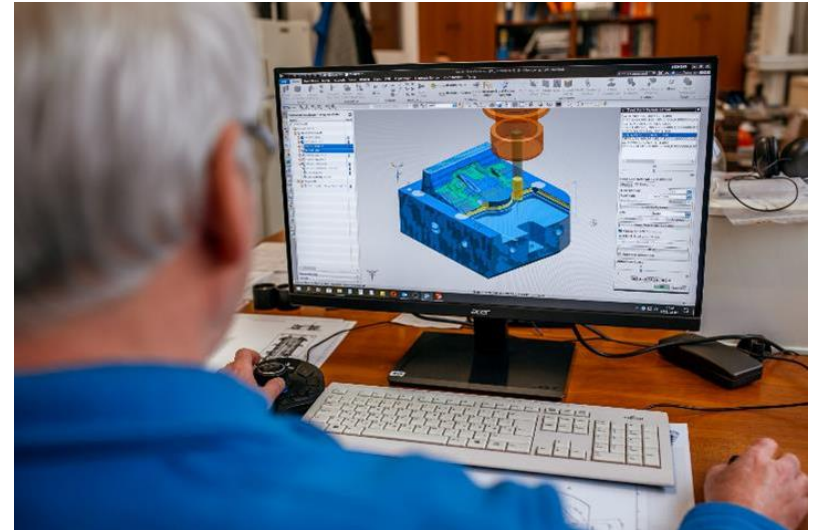
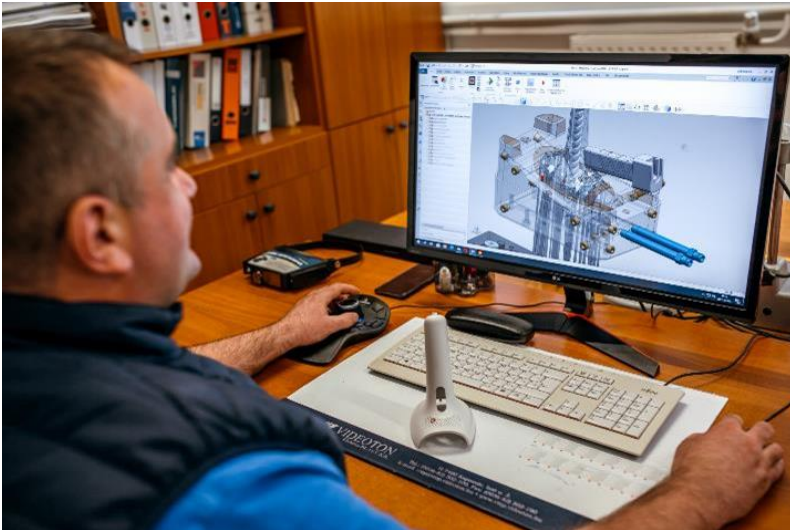

INTERNAL TOOLSHOP

Competence

- CNC lathe
- CNC milling
- grinding
- cylindrical grinding
- laser welding
- laser engraving
- EDM machines: wire & block
- toolmakers

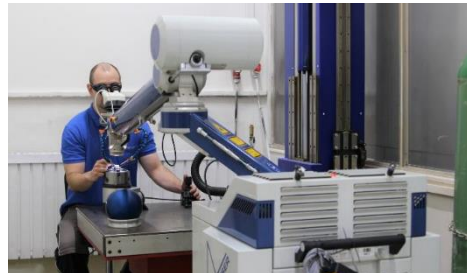

COOPERATION WITH HUNGARIAN UNIVERSITIES

Budapest University of Technology and Economics



- design plans
- ergonomic & hydrodynamic evaluation

John von Neumann University – GAMF Faculty of Engineering and Computer Science



- cooperation in tenders (market R+D tender)
- battery welding optimisation, analysis, technological development
- metallographic examinations
- testing of plastics (MFI/MVR, TG examination)

University of Pécs – Faculty of Engineering and Information Technology



Pécsi Tudományegyetem
Műszaki és Informatikai Kar

- cooperation in dual engineer training

Széchenyi István University (Győr)



- external product approval assessments (packaging of plastic and metal parts, finished goods)
- climatic, salt-spray and ageing tests

Hungarian University of Agriculture and Life Sciences – Kaposvár Campus



- comparison of household devices with different technical content from the aspect of influence for raw materials (colour, flavour, fragrance, content)

COOPERATION WITH EXTERNAL LABS

TÜV Rheinland



- extensive association with the company
- total RoHs and REACH inspections
- analysis of components food contact components
- continuous communication in connection with approval process topics (in product development stage)
- tests in connection with product validation (climate-,vibrating-,battery electric-,combined tests...)
- UN38-3 / IEC 62133 tests and issue of certificates
- CE marking

THANK YOU FOR YOUR KIND ATTENTION!



VIDEOTON Elektro-PLAST Kft.
H-7400 Kaposvár
3 Izzó Str.
Phone: + 36 82 502 100
vtep@vtep.videoton.hu

Simon Patkás
Engineering Manager
Phone: + 36 82 502 341
Mobile: + 36 20 403 2590
patkas.simon@vtep.videoton.hu

